

Silver H600S/HFF600S



Your choice of either the standard Manual (H600S), Power Up & Power Down (with Manual Release), or the Muir's Patented Auto Free Fall (HFF600S), or Free Fall with Manual Release are all available.

Designed for vessels 5-8m (16-26ft) and offering fast powered retrieval, smooth rope chain combination operation, reduced installation time, style and unbeatable reliability. Ideal for recreational users and for serious fishermen.

The H600S/HFF600S will weather the harshest of conditions and is backed by Muir's three year warranty and supported by an extensive worldwide service network.

Model	H600S & HFF600S
VESSEL LENGTH	5-8m 16-26ft
POWER SUPPLY (DC)	12V
MOTOR (Watts)	400
MAX LOAD	220kg 484lb
WORK LOAD	60kg 132lb
AMPS WORK LOAD	60
MAX LINE SPEED	23m/min 75ft/min
CHAIN SIZE	6mm (1/4")
CORE #116	Australian Shortlink and DIN 766
CORE #117	HT, 3B
ROPE SIZE (3PLY)	12mm 1/2"
NET WEIGHT	9kg 20lb

Features

- Powerful 400w/12v DC permanent magnet motor coupled to heavy duty gearbox, offering greater pulling power and longevity
- Muir's anodized aluminium housing and top coat with quality AWL GRIP silver metallic finish looks stylish and made to last in the harshest of environments
- SS316 components, including SS316 Clutch Cap, Stripper and Peeler
- HFF600S with Muir's patented FreeFall design
- Motor & gearbox combination with CRC Soft Seal covering film provides additional protection and trouble free operation
- Simple above deck unit for the easiest of installations and minimal intrusion into the chain locker
- Compact design perfectly suited where deck area or chain locker space and depth is at a premium
- Designed and made in Australia

Standard package comprises

- Circuit breaker & mounting panel w/ LED
- Helm control rocker switch & mounting panel
- Reversing solenoid kit - 12v 2-4 pole
- Clutch release handle
- Installation & operation manual
- Deck mounting studs & fasteners



H600S/HFF600S

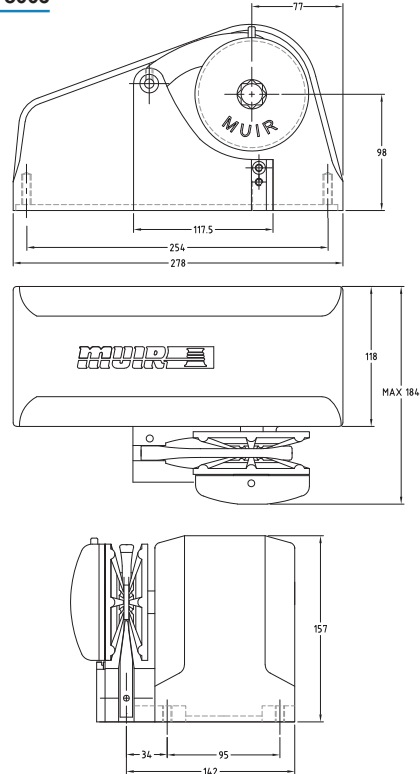

HFF600

